



LSX Series

Programmable Low Power AC Source 1,500VA up to 6kVA

High Performance Low Power AC Source & Frequency Converter



Key Specifications

- Single, Split, Three-Phase
- 1.5kVA to 2kVA models in 3U
- 4.5kVA to 6kVA models in 5U
- Voltage Range: 0 – 135VAC L-N
- Transformer Options: up to 2.5x
- Frequency: 15 - 1,200Hz

Highlights

- PWM Switch Amplifier Technology (Compact, Smaller, Lighter)
- Full Current at Low Voltage and Low PF
- Phase Angle Programming on 3Ø Models
- 0 to 1 PF loads – Linear, Non-linear and Reactive
- Programmable Impedance
- Precise Output Voltage & Load Regulation
- Metering of Volts, RMS Current, Peak Current, Apparent & True Power
- Harmonics Measurements
- Advanced Scope Function
- Sine, Square, Triangle, Clipped Sine & Arbitrary Waveforms
- Transients Prog. (LIST, PULSE, STEP)
- Full Galvanic Isolation
- Safety Programmability Limits
- **SmartSource Suite** Control Platform
- Compatible with Legacy UPC Controllers

LSX Series Overview

The LSX Series AC Power Source is designed for low power, ranging from 1.5kVA/kW up to 6kVA/kW in single and three phase. This AC power source has an advanced PWM programmable controller and is a cost-effective option for frequency conversion, advanced power line disturbance tests, aerospace compliance, ATE, appliances, and UPS applications. Output power ratings are based on the worst case combination of input line, output voltage, power factor, and temperature.

See Economy M Version for applications requiring reduced functions.

Application Examples:

- Aerospace & Defense
- Industrial, Semi-Conductor, UPS Power Supplies
- Medical, White Goods, Appliances, HVAC, Lighting
- Unidirectional AC/DC Applications

Key Advantages



Proven & Reliable
Power



Precise Output Voltage
& Load Regulation



Advanced Transients &
Programming



Full Current at Low Voltage
& Low PF



Automated Test Equipment for Military & Defense Testing

Growing demand for power to support increasingly complex avionics, radar and weapons systems means more power is needed in less available space. The new LSX Series addresses this need by offering unmatched AC power quality output.

With extensive control over voltage, current, frequency, phase angles and transients, the LSX series is capable of handling complex Test Program Sets (TPS's) with minimal programming effort. Available in a range of power levels and output phase configuration to meet any AC test requirement up to 6000 VA.



Aerospace & Avionics Testing



The low noise and low distortion analog power conversion technology used in the LSX Series Power Source results in unmatched voltage quality and high peak current capability. A frequency range of 15Hz to 1200Hz supports both 400Hz fixed frequency as well as 360Hz to 800Hz wild frequency development and test with exceptional harmonics support.

For compliance testing to electrical avionics test standards like RTCA/DO160 Section 16 and Mil-Std 704, Windows 10 test software test sequences are available as an option.

Appliances, HVAC, UPS Power Supplies, Medical Equipment

The LSX Series AC power source is ideal for testing low power appliances, HVAC, lighting, UPS power supplies and medical equipment due to its precise and flexible voltage control, high output capabilities, and versatility. It can simulate a wide range of real-world conditions, including both direct and transformer-coupled voltage outputs, to match the specific needs of different devices.

This makes it a powerful tool for verifying the performance and compliance of these systems under various operating conditions.



Simplify Test with Multiple Control Options

Easily access and control the unit through the front panel, USB, or via Ethernet (LAN) on any web browser.

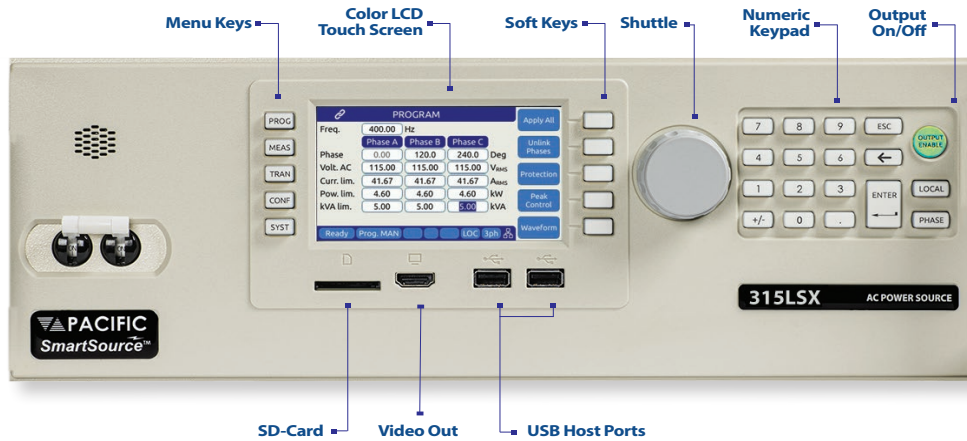

Programming

PROGRAM				Apply All
Freq.	400.00 Hz			Unlink Phases
Phase	Phase A	Phase B	Phase C	
	0.00	120.0	240.0	Deg
Volt. AC	115.00	115.00	115.00	V _{RMS}
Curr. lim.	41.67	41.67	41.67	A _{RMS}
Pow. lim.	4.60	4.60	4.60	kW
kVA lim.	5.00	5.00	5.00	kVA
Ready Prog. MAN				Protection
				Peak Control
				Waveform

Metering

MEASUREMENTS 1 OF 2				Meas. Page 2
Freq.	400.00 Hz			Fault Status
Phase	Phase A	Phase B	Phase C	
Volt. L-N	115.00	115.00	115.00	V _{RMS}
Current	25.67	25.67	25.67	A _{RMS}
Power	2.655	2.555	2.655	kW
	V _{AB}	V _{BC}	V _{CA}	
Volt. L-L	199.20	199.19	199.20	V _{RMS}
Ready Prog. MAN				Real Time Plot
				Individual Phase

SmartSource Suite, Built-In

Breakthrough Remote Control Platform for Enhanced Visualization & Control

The SmartSource Suite is an embedded web server that allows you to fully access and control Pacific Power Source products on any web browser, in real-time with an enhanced user experience and visualization tools.

Its intuitive user-interface, full access to all test functions, and easy programming capabilities substantially reduce test time and increase productivity.

- Enhanced Visualization
- Intuitive Test Creation & Execution
- Pre-Written Test Sequences
- Usability Without Limits



Access SmartSource Suite on Any Web Browser in Real-Time

The Benefits of a PWM Amplifier Topology

PWM AC Power Sources offer very good density, high efficiency, and perform well into low power factor loads. They use a combination of both linear and non-linear methods to achieve high efficiency conversion in lighter and smaller packages.

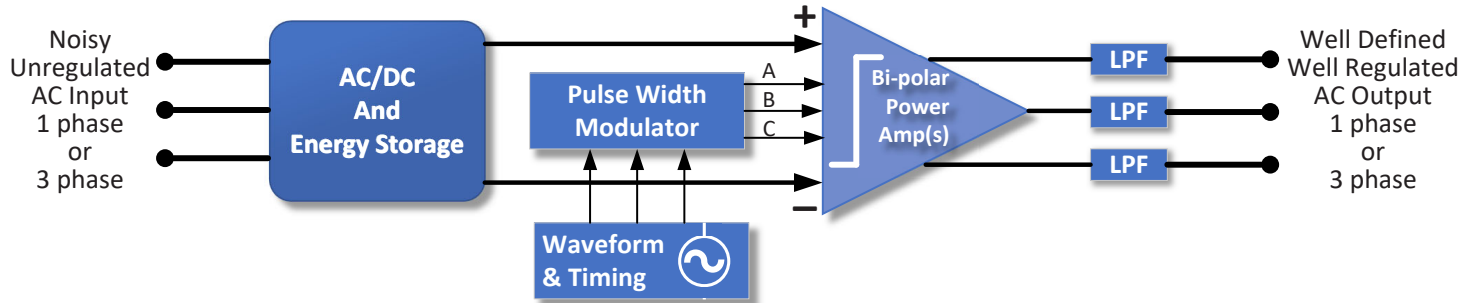

BENEFITS
Moderately low output distortion
Full current into very low power factor reactive loads
Lower weight due to higher amplification efficiencies
Smaller size compared to Linear AC Sources

FEATURE/CAPABILITY	SWITCH MODE TECH
Highest amplifier efficiency	✓
Lowest operating temperature	✓
Lowest weight	✓
Smallest size	✓
Lowest cost	✓
Low-power factor handling	✓

Output Phase Modes

Three phase LSX Models can be configured to operate in one of three available phase modes or FORMs:

Single Phase

Enables Single phase output with the load connected between the 1 Phase and Neutral output terminals. Voltages are programmed phase to neutral.

Split/Single Phase

Enables high range Split/Single phase output. Load is connected either between the Phase A and Phase B output terminals (full voltage) or Phase and Neutral (half voltage). Voltages are programmed phase to phase.

Three Phase

Enables Three phase output with the load connect between the A, B, C, and Neutral terminals. Loads may be connected either line to line or line to neutral. Voltages are programmed phase to neutral.

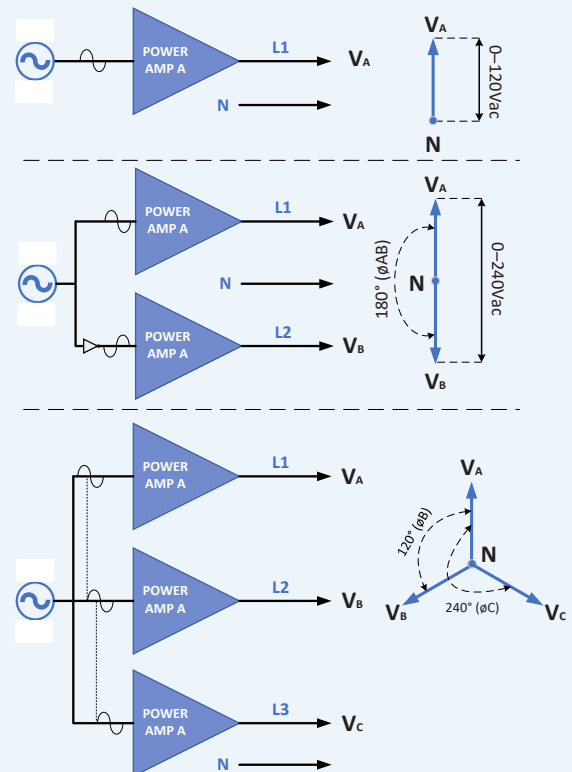

Wide Selection of Voltage Ranges

All LSX Series models support direct coupled output voltages up to 135VLN or 270VLL (single phase) or 135VLN/234VLL (three phase).

Transformer Option

For higher voltages, the T-Option transformer offers output ranges with ratios of 1.5:1, 2.0:1, or 2.5:1, providing up to 600VLL in split phase or 585VLL in three phase.

Switching between direct and transformer coupled voltages is automatic, eliminating the need to

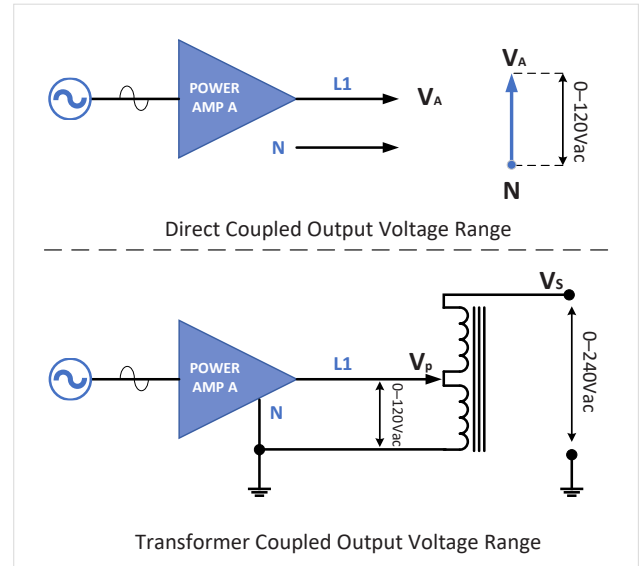

Easy to Use, Advanced Programming Capability

The built-in **SmartSource Suite** simplifies execution of test sequences. In this avionics application example, we are building a transient waveform at 115Vac, 400Hz using the LSX Series.

The user can easily enter various parameters and evaluate the waveforms using multiple windows on a web browser to increase productivity.

The LSX Series is dynamic and efficient, providing low output distortion.

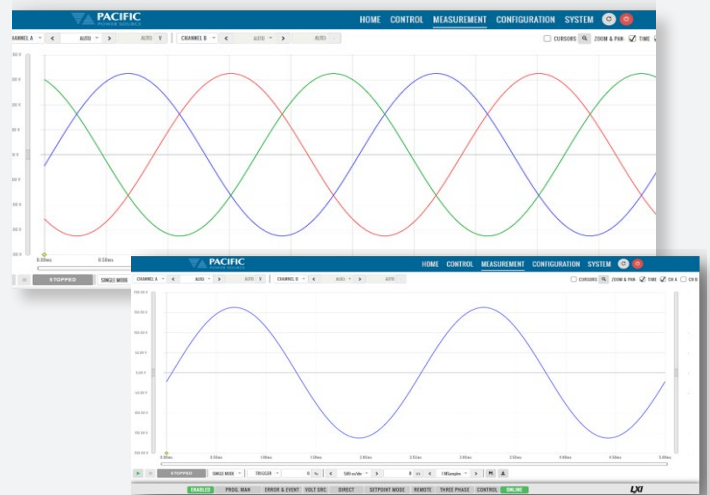

Easily build simple to complex transient waveforms

PROGRAM		SELECTED PHASE	
OUTPUT ENABLE	ON	PHASE	A
FREQUENCY	400.00 Hz	CURRENT LIMIT	3.00 Arms
VOLTAGE AC	115.00 Vrms	POWER LIMIT	30.00 W
		VA LIMIT	30.00 VA
MEASUREMENTS		Phase A	Phase B
FREQUENCY	400.00 Hz	400.00 Hz	400.00 Hz
VOLTAGE L-N RMS (AC-DC)	115.00 Vrms	115.00 Vrms	115.00 Vrms
VOLTAGE L-N RMS (AC)	115.00 Vrms	115.00 Vrms	115.00 Vrms
VOLTAGE L-N THD	0.03 %	0.02 %	0.03 %
VOLTAGE L-N DC	-0.01 Vdc	0.01 Vdc	0.00 Vdc
CURRENT RMS (AC-DC)	0.00 Arms	0.00 Arms	0.00 Arms
CURRENT RMS (AC)	0.00 Arms	0.00 Arms	0.00 Arms
CURRENT THD	0.00 %	0.00 %	0.00 %
POWER	0 W	0 W	0 W
WATT HOUR	0.000 kWh	0.000 kWh	0.000 kWh
ELAPSED TIME	0.00 min	0.00 min	1h 5m 21s
APP POWER	0 VA	0 VA	0 VA
POWER FACTOR	0.00	0.00	0.00

View waveforms on multiple windows on a web browser in real-time.

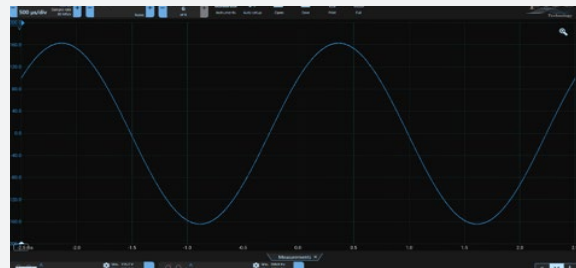

External Pico Scope

Transient Programming

Voltage, Waveform and Frequency output transients are easily created from the front panel using an intuitive spreadsheet style data entry method. Data may be entered for a specific phase or for all three phases at the same time.

Create voltage, waveform, and frequency transients easily via the front panel or web interface using LIST, PULSE, or STEP modes. Edit, store, and execute transients in non-volatile memory.

TRANSIENT VIEW				
#	Freq	Volt AC	Volt DC	Dwell
1	400.00	115.00	0.00	100.0
2	400.00	100.00	0.00	10.0
3	400.00	115.00	0.00	100.0
4	400.00	100.00	0.00	10.0
5	400.00	115.00	0.00	100.0
6	400.00	100.00	0.00	10.0
7	400.00	115.00	0.00	100.0
8	400.00	100.00	0.00	10.0

Ready Prog. MAN LOC 3ph

Run Step Step Mode Edit Mode Run Screen

Transient Executing in View Mode



LIST MODE

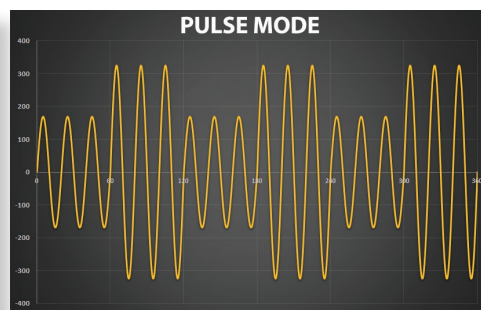

PULSE MODE

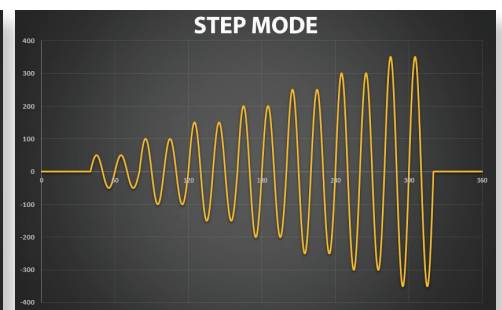

STEP MODE

Advanced Scope Capture

The LSX Series supports diverse AC power tests with full control over voltage, current, frequency, power, slew rates, and phase angles.

Ideal for compliance, transformer, appliance, DC charger, and UPS testing. Scope images show example waveforms.



Three Phase Unbalance Voltage Test Captured

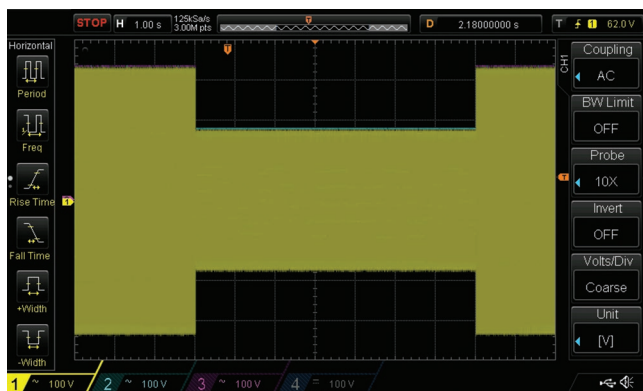

Three Phase Voltage Drop Test Captured

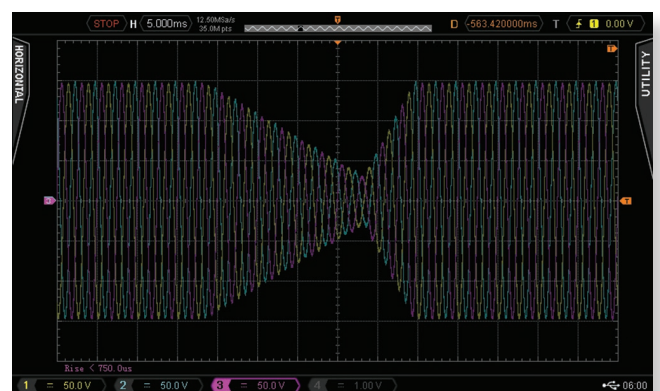

AC Transient Output Captured on Digital Scope

Select from Library of 200 Arbitrary Waveforms

LSX Series offers sine, clipped sine, square, triangle, and custom waveforms. Create and preview arbitrary waveforms via SmartSource Suite web browser with named aliases for easy selection.

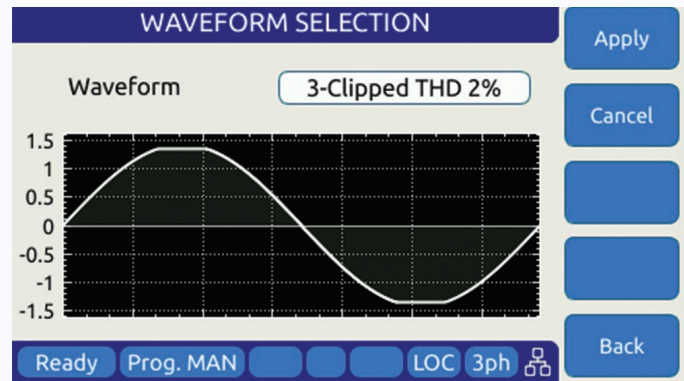

Clipped Sine Waveform Selection - Vthd = 2%

Capture Voltage and Current Waveforms

Built-in digital scope function captures voltage and current time domain signals, perfectly synchronized to the output frequency. Voltage and current displayed with accurate phase relationship. Display output waveforms on front panel or in Web browser.

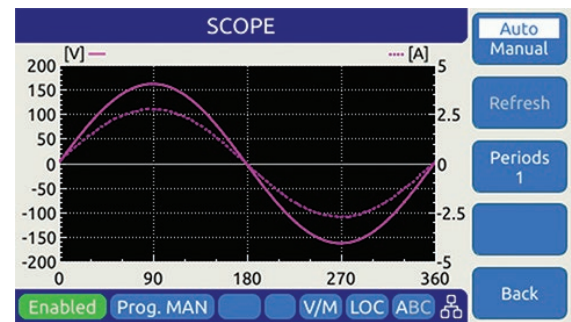

Harmonic Measurements

Eliminate the need for an external power analyzer by measuring voltage and current harmonics. Harmonics information is displayed in either bar charts or detailed table format for easy viewing and analysis.

Data is displayed for individual phase or all three phase simultaneously.

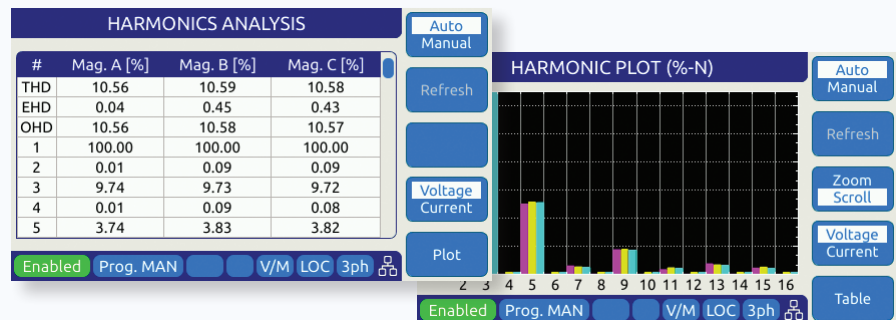

Auxiliary I/O Functions

To support integrated test system design and interaction with the load or other equipment, the LMX Series offers a range of analog and digital I/O functions.

User Programmable I/O. Assign command macros or programming parameters to analog or digital I/O pins as needed. This provides a unique level of customization for putting together sophisticated test stations.



Single-Phase Models

Direct Coupled Output Units (15 Hz - 1200 Hz)

MODEL	Rated Power (VA) ¹	Output Form ²	Output Voltage Max ³ (I-n/I-I)	Output Current ⁴ (A _{rms})	Input Power ⁵	Unit Height (in.-U)	Unit Weight (lbs/kg)
115LSX	1500	1	0-132	16	1Ø	5.25-3U	65/29.5
120LSX	2000	1/2	0-150/300	20/14	1Ø	5.25-3U	75/34
140LSX	4000	1/2	0-135/270	32/16	3Ø	8.75-5U	120/54.5
160LSX	6000	1/2	0-132/264	48/16	3Ø	8.75-5U	145/66

Direct / Transformer Coupled Selectable Output Units (45 Hz - 1200 Hz)

MODEL	Rated Power (VA) ¹	Output Form ²	Output Voltage Max ³ (I-n/I-I)				Output Current ⁴ (A _{rms})				Input Power ⁵	Unit Height (in.-U) Weight (lbs/kg)	Transformer Height (in.-U) Weight (lbs/kg)
			Direct	Transformer			Direct	Transformer					
				Ratio 1.5:1	Ratio 2.0:1	Ratio 2.5:1		Ratio 1.5:1	Ratio 2.0:1	Ratio 2.5:1			
115LSXT	1500	1	0-132	0-198	0-264	0-330	16	10.7	8	6.4	1Ø	5.25-3U 80/36.4	Integrated
140LSXT	4000	1/2	0-135/270	0-202/404	0-270/540	0-338/600	32/16	21.3/10.7	16/8	12.8/6.4	3Ø	8.75-5U 120/54.5	5.25-3U 125/56.8
160LSXT	6000	1/2	0-132/264	0-198/396	0-264/528	0-330/600	48/16	32/10.6	24/8	19.2/6.4	3Ø	8.75-5U 145/66	5.25-3U 125/56.8

1. Rated output power is based on a combination of output voltage, current and load power factor. Values stated represent the rated capabilities of a given model. Consult factory for assistance in determining specific unit capabilities as they might apply to your application.
2. All single phase output units (Model 115 ASX excepted) are operable with dual voltage ranges as listed. Output voltage ranges and 1Ø/2Ø output form are selected by front panel or bus commands.
3. Output voltage ranges listed are for standard units. VMAX is output voltage with nominal input and full rated load applied. Other voltage ranges are available with the output magnetics options below.
4. Available current will vary with output voltage and power factor.
5. Input power frequency is 47-63 Hz. Single phase input: 100, 110, 120, 208, 220, 230 and 240 VAC +10%. Three phase input: 208, 220, 240, 380, 400 and 416 VAC +10%.
6. Single phase and 400 Hz input options may be available. Consult Factory.

LSXM Version Reduced Feature Set Summary

FEATURES	LSX	LSXM
Output Waveforms	See Page 10	Sinewave only
Phase Angles phase B, C	Programmable	Fixed: 120°, 240° or 240°, 120°
Transient Programming	yes	no
Programmable V,F slew rate	yes	yes
Programmable Settings	yes	yes
Measurements (scalar)	yes	yes
Harmonic Measurements	yes	no
Waveform Capture	yes	no
Programmable output Impedance (Prog-Z)	yes	no
Digital control interfaces	yes	yes
Embedded Web Server	yes	yes



115LSX Model - 1500VA - 3U (5.25")



120LSX Model - 2000VA - 3U (5.25")



140LSX Model - 4000VA - 5U (8.75")

Three-Phase Models

Direct Coupled Output Units (15 Hz - 1200 Hz)

MODEL	Rated Power (VA) ¹	Output Form ²	Output Voltage Max ³ (I-n/I-l)	Output Current ⁴ (A _{rms})	Input Power ⁵	Unit Height (in.-U)	Unit Weight (lbs/kg)
315LSX	1500	1/2 3	0-132/264 0-132/228	12/6 4/Ø	1Ø	5.25-3U	75/34
320LSX	2000	1/2 3	0-150/300 0-150/260	20/12 7/Ø	1Ø	5.25-3U	85/38.5
345LSX	4500	1/2 3	0-135/270 0-135/234	36/12 12/Ø	3Ø	8.75-5U	145/66
360LSX	6000	1/2 3	0-132/264 0-132/228	48/16 16/Ø	3Ø	8.75-5U	145/66

Direct / Transformer Coupled Selectable Output Units (45 Hz - 1200 Hz)

MODEL	Rated Power (VA) ¹	Output Form ²	Output Voltage Max ³ (I-n/I-l)			Output Current ⁴ (A _{rms})			Input Power ⁵	Unit Height (in.-U) Weight (lbs/kg)	Transformer Height (in.-U) Weight (lbs/kg)		
			Direct	Transformer		Direct	Transformer						
				Ratio 1.5:1	Ratio 2.0:1		Ratio 2.5:1	Ratio 1.5:1				Ratio 2.0:1	Ratio 2.5:1
345LSXT	4500	1/2 3	0-135/270 0-135/234	0-202/404 0-202/350	0-270/540 0-270/468	0-338/600 0-338/585	36/12 12/Ø	24/8 8/Ø	18/6 6/Ø	14.4/4.8 4.8/Ø	3Ø	8.75-5U 145/66	5.25-3U 125/56.8
360LSXT	6000	1/2 3	0-132/264 0-132/228	0-198/396 0-198/343	0-264/528 0-264/457	0-330/600 0-330/572	48/16 16/Ø	32/10.7 10.7/Ø	24/8 8/Ø	19.2/6.4 6.4/Ø	3Ø	8.75-5U 145/66	5.25-3U 125/56.8

1. Rated output power is based on a combination of output voltage, current and load power factor. Values stated represent the rated capabilities of a given model. Consult factory for assistance in determining specific unit capabilities as they might apply to your application.
2. All three phase units are operable as single phase with dual voltage range capability or as three phase. Output voltage ranges and 1Ø/3Ø output form are selected by front panel or bus commands.
3. Output voltage ranges listed are for standard units. VMAX is output voltage with nominal input and full rated load applied. Other voltage ranges are available with the output magnetics options below.
4. Current ratings at 125Vrms output. Current may vary with power factor.
5. Input power frequency is 47-63 Hz. Single phase input: 100, 110, 120, 208, 200, 220, 230 and 240 VAC +10%. Three phase input: 208, 220, 240, 380, 400 and 416 VAC +10%. (480V input or 400 Hz frequency input available as a cost option on most ASX models.
6. Single phase and 400 Hz input options may be available. Consult Factory.



315LSX Model - 1500VA - 3U (5.25")



360LSX Model - 6000VA - 5U (8.25")



360LSXT Model - 6000VA with Mag Module - 8U (14")

Technical Specifications

OUTPUT		SPECIFICATION	
Power			
Output	See Model Tables page 8 & 9		
Voltage			
Mode	AC		
Direct Coupled Range ¹	See Model Tables page 8 & 9		
T-Option Ranges	Turns ratios: 1.5:1, 2.0:1, 2.5:1		
Programming Resolution	0.01 V		
Accuracy	±0.1% (CSC mode)		
Waveforms (200 Max.)	Sine, Square, Triangle, Clipped (THD), Arbitrary		
DC Offset	< 20 mV		
Harmonic Distortion (Vthd)	Form 1	Form 3	
3U Models 15 - 200 Hz	< ± 0.25%	< ± 0.25%	
200 - 1200 Hz ²	< f x 0.7% + 0.36%	< f x 0.7% + 0.11%	
120/320LSX 15 - 200 Hz	< ± 0.25%	< ± 0.25%	
200 - 1200 Hz ²	< f x 0.7% + 0.11%	< f x 0.7% + 0.11%	
5U Models 15 - 200 Hz	< ± 0.25%	< ± 0.25%	
200 - 1200 Hz ²	< f x 1.4% + 0.22%	< f x 1.4% + 0.03%	
Note:	Under full, resistive load conditions		
Output Noise	-66 dB		
Load Regulation	Form 1	Form 3	
3U Models 15 - 200 Hz	< ± 0.25%	< ± 0.25%	
200 - 1200 Hz ²	< f x 0.7% + 0.11%	< ± 0.5%	
120/320LSX 15 - 200 Hz	< ± 0.25%	< ± 0.25%	
200 - 1200 Hz ²	< ± 0.6%	< ± 0.5%	
5U Models 15 - 200 Hz	< ± 0.25%	< ± 0.25%	
200 - 1200 Hz ²	< f x 2.5% - 0.25%	< f x 1.5% - 0.05%	
Line Regulation	< 0.1% for 10% Line Change		
Voltage Sense	External Sense, max. voltage drop 5% F.S.		
Voltage Response Time	60 µsec typical, 10–90% load step		
Isolation			
Output Neutral to Chassis	150Vac Max.		
Output Line to Chassis	338Vac Max.		
Frequency			
Direct Coupled Range	15.00 – 1200.0 Hz		
T-Option	45.00 – 1200.0 Hz		
Programming Resolution	0.01 Hz		
Accuracy	± 0.005% / 50 ppm		
Current			
Range	See Model Tables page 8 & 9		
Programming Resolution	0.01 Arms		
Accuracy ³	± (0.5% + f (kHz) * 0.5%) F.S.		
Current Protection (CP) Modes	Constant Current (CC) or Output Trip (CV)		
Phase Angle (In 3 and 2 Phase Mode)			
Programmable Phase (B, C)	0 - 359.9°		
Resolution	0.1°		
Accuracy	±0.35° / ±0.1° Phase Reg. Mode		
Programmable Impedance			
Available Modes	Real-time mode, RMS mode		
Phase Mode	1 Phs / 3 Phs	2 Phs	
Resistance (R)	±100 Ω	±200 Ω	
Inductance (L)	0 - 2 mH	0 - 4 mH	

TRANSIENTS	Specification
Programming	
No. of Entries	200 Steps / 400 segments
Modes	LIST, PULSE, STEP
Parameters	Frequency, Volt AC, Volt DC, Waveform, Ramp Time, Dwell Time
Dwell Time Range	0.2 - 10000000.0 msec
Time Resolution	0.1 msec
Edit Modes	Add at end, Insert before, Delete
Execution	
Run Control	Run from step # to step # Run, Step, Restart, Stop
Execution Modes	Normal, Debug
Program Storage	
Non-volatile	100 Programs + Transients

MEASUREMENTS	SPECIFICATION
AC Voltage (Vrms)	
Range	0 – 340 VLN / 0-600 VLL
Resolution	0.01 V
Accuracy	± 0.1% F.S.
Frequency (Hz)	
Fundamental Range	15 - 1200 Hz
Resolution	0.01 Hz
Accuracy	± 0.1% Rdg
AC Current (Arms)	
Range	See Model Tables page 8 & 9
Resolution	0.01 Arms
Accuracy	± (0.5% + f (kHz) * 0.5%) F.S.
Current Crest Factor	
Range	1.00 - 5.00
Resolution	0.01
Accuracy ¹	± 2.0% F.S.
AC or DC Power (W)	
Range	See Model Tables page 8 & 9
Resolution	1 W front panel / 0.1 W remote
Accuracy	± 0.75 % F.S.
Apparent Power (VA)	
Range	See Model Tables page 8 & 9
Resolution	1 VA front panel / 0.1 VA remote
Accuracy ¹	± 0.75 % F.S.
Power Factor	
Range	0.00 - 1.00
Resolution	0.01

Note 1: Specification valid above 40Hz

WAVEFORM CAPTURE	SPECIFICATION
Parameters	VLN-A, VLN-B, VLN-C, VLL AB, VLL AC, VLL BC, IA, IB, IC
Max. Sample Rate	500 ksps
Samples/cycle	1024 (512 in UPC Compatibility mode)
Record Length	8 MSamples
Bandwidth	100 kHz @ 500 ksps

Note 1: VLL applies to three phase LSX Models in three phase mode

Note 2: Frequency "f" is in kHz



Note 3: Specification valid above 40Hz

HARMONICS MEAS.	SPECIFICATION
Parameters	VLN-A, VLN-B, VLN-C, VLL AB, VLL AC, VLL BC, IA, IB, IC
Harmonics Range	H2 ~ H50
Accuracy – Amplitude	± 1.0 % of RMS Reading
Phase Angle Range	0 ~ 359.9
Accuracy - Phase Angle	< 8 µsec
Bandwidth	100 kHz @ 500 ksps
Display Modes	Table format, Graph format

AC INPUT	SPECIFICATION
Mains Voltage Form	4 Wire, L1, L2, L3 and PE
Frequency	47 - 63 Hz
Single Phase AC Input Selections	
Input Voltages	100, 110, 120, 200, 208, 220, 230 or 240 Vac
Phase Current	Model specific
Three Phase AC Input Selections	
Input Voltages	208, 220, 240, 380, 400, 416 or 480 ¹ Vac
Phase Current	Model specific

ENVIRONMENTAL	SPECIFICATION
Cooling	Variable speed fan cooled, front and/or side air intake, rear exhaust. 115/120/315/320 Models: 200 CFM 140/160/345/360 Models: 300 CFM
Audible Noise	65 dBA Max. @ 1 meter
Temperature	
Operating	0 to 55 °C / 32 to 131 °F
Storage	-10 to 70 °C / 14 to 158 °F
Humidity	< 0 - 95 %, non-condensing
Altitude	Operating: 1,981 m / 6500 feet Storage: 12,192 m / 40,000 feet

SYSTEM FEATURES	DESCRIPTION
DISPLAY	
Type	Full Color, Touch LCD Display
Size	4.3" Diagonal
Resolution	480 x 272 pixels
USB Ports	2 Front Panel, 1 Rear Panel, Type A
SD Card	32 GB max. Capacity
Video Output	Monitor Out, Front Panel

INTERFACES	DESCRIPTION
Remote Control	
USB	Device Type B
RS232	1200 - 921600 baud
 LAN	LXI compliant, Ethernet, RJ45, TCP/IP Protocol, Telnet Protocol Command Line
 GPIB	IEEE488.1, IEEE488.2 (2003 incl., NI HS488) IEC 60488-1, IEC 60488-2 (2004) Functions: SH1, AH1, T6, L3, SR1, RL1, DC1, DT1

Note 1: 480Vac Input is an available option on some models. Consult factory.

ANALOG I/O	SPECIFICATION
Analog Inputs (4)	
Modes	Amplifier, Amplitude Modulation, Int. + Ext. Input Summing
AI1, AI2, AI3	Programmable setting phs A, B, C
AI4	Programmable
Range	-10V to +10V
Accuracy	± 0.1% F.S.
Impedance	AI1, 2 & 3: 7.2 kOhm, AI4: 5.0 kOhm
Analog Outputs (4)	
AO1, AO2, AO3, AO4	User defined measurement functions.
Range	0 - 5 Vdc for 0 - F.S.
Accuracy	± 0.1% F.S. into > 5 kOhm load
Impedance	< 10 Ohm
Connector Type	DB25, Rear Panel

DIGITAL I/O	SPECIFICATION
Digital Inputs (6)	
Fixed (3)	Remote Inhibit, Transient Trigger, Phase Sync
User Programmable (3)	DI1, DI2, DI3
Input Levels	Low < 0.4V, High > 2.0V
Digital Outputs (6)	
Open Collector, Fixed (2)	Relay Control FORM, Relay Control T Option
TTL, Fixed (2)	Output Relay/Transient /Function Strobe Phase Sync
User Programmable (2)	DO1, DO2
Output Levels	Low < 0.4V, High > 4.6V
Connector Type	DB25, Rear Panel

MECHANICAL	SPECIFICATION
Dimensions	
Width	19" / 482 mm
Height	See Model Tables page 8 & 9
Depth	3U Models: 23.0" / 584 mm 5U Models: 23.12" / 587 mm
<i>(Includes rear connectors, excludes rack handles)</i>	
Weight	
Net	See Model Tables page 8 & 9

PROTECTION	SPECIFICATION
Types	AC or DC Current, True Power, Apparent Power, Over Voltage, Over Temperature

REGULATORY	SPECIFICATION
Safety	IEC 61010-1:2010 (Edition 3)
EMC	
Emissions Standard	EN 55011:2009+A1:2010
Immunity Standard	EN 61000-4-2, -3, -4, -5, -6, -8, -11
Product Category	EN 61326-1:2013 (Measurement, Laboratory and Control Equipment)
Approvals (Option)	CE Mark, NRTL Safety
RoHS (DIRECTIVE 2011/65/EU)	
Product Category	EN50581:2012

Ordering Information

Single Phase Models (T = Option)

- 115LSX(T) 115LSXM(T)
- 120LSX 120LSXM
- 140LSX(T) 140LSXM(T)
- 160LSX(T) 160LSXM(T)

Three Phase Models (T = Option)

- 315LSX¹ 315LSXM
- 320LSX¹ 320LSXM
- 345LSX(T) 345LSXM(T)
- 360LSX(T) 360LSXM(T)

AC Input Voltages (V_{IN})

- Must be specified on order, see pages 8 & 9

Options

- C Interharmonics Generator Option
- E Export version, "E" postfix

Order Example

- 360LSX
- AC Power Source, 6000VA, 3-Phase, No T-Option, USB, RS232, LAN, GPIB & AUX I/O
 - Specify Factory set AC Input Voltage
 - Specify if CE or NRTL certification is needed

Note 1: For External Transformer option on 315LSX & 320LSX models, refer to option M99222

Typical Delivery Items

- AC Power Source
- English Manuals in PDF Format
- Certificate of Compliance
- Optional CE Mark (CE2 or CE4) or optional NRTL (must be specified on order)

Model Number Configurator¹

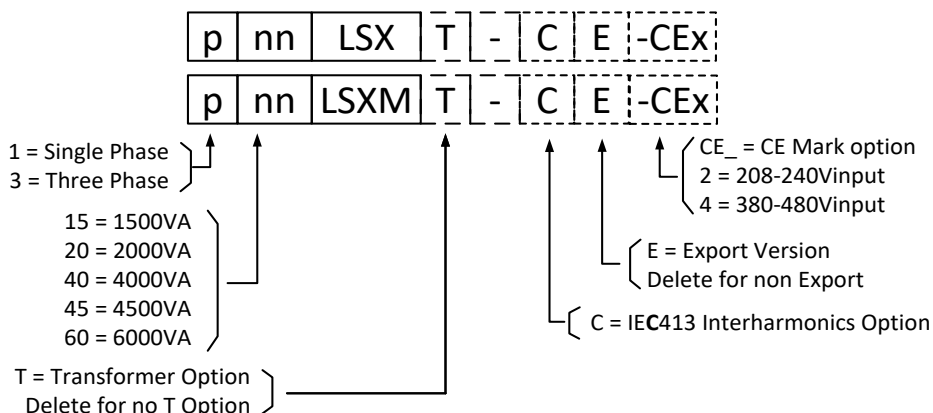

Pre-Written Test Sequence Options

Test Sequence Options require use of the built-in **SmartSource Suite** remote control platform via LAN or USB.

Test Sequences - Avionics²

- ABD0100.1.8 - Airbus A380, AC Power Groups
- ABD0100.1.8.1 - Airbus A350, AC Power Groups
- AMD24C - Airbus A400M, AC Power Groups
- Boeing 787B3-0147 - B787, AC Power Groups
- MIL-STD704 - US DoD, AC Power Groups
- RTCA-DO160 Section 16, AC Power Groups

Test Sequences - Other²

- IEC Test Suite - Includes IEC61000-4-11p, IEC61000-4-14, IEC61000-4-27p, IEC61000-4-28 and IEC61000-4-34p
- IEEE 1547.1
- MIL-STD 1399-300B - US DoD
- MIL-STD 1275 Rev E
- SEMI F47-0706
- KS C 9610 4-11, KS C 9610-4-29

Worldwide Service & Support

NORTH AMERICA

Pacific Power Source, Inc.
Irvine, USA

Phone: +1(949) 251-1800
Fax: +1 (949) 756-0756
Email: sales@pacificpower.com
Web: www.pacificpower.com

EUROPE

Pacific Power Source
Europe GmbH.

Kappelrodeck, Germany
Phone: +49 7842 99722-20
Fax: +49 7842 99722-29
Email: info@pacificpower.eu

UNITED KINGDOM

Caltest Instruments Ltd.
Petersfield, UK

Phone: +44 (0) 1483 302 700
Email: sales@caltest.co.uk

CHINA

PPST Shanghai Co. Ltd.
Shanghai, China

Phone: +86-21-6763-9223
Fax: +86-21-5763-8240
Email: info@ppst.com.cn



Caltest Instruments GmbH

Binzigstrasse 21 | Tel: +49(0)7842-99722-00
D-77876 KAPPELRODECK | Fax: +49(0)7842-99722-29
www.caltest.de | info@caltest.de

2802 Kelvin Avenue, Suite 100
Irvine, CA 92614 -5897 USA
Phone: +1 949.251.1800
Toll Free: 800.854.2433
E-mail: sales@pacificpower.com
Web: www.pacificpower.com